



**Sub Annex B\_5 – Duct Access Service**  
**FIRST DRAFT**

**Document No:**

**Issue Date:**

**Classification:**

**Documentation security classification applies to this document**

## i Document Authorization

<b>Reviewed by</b>	<b>Approved by</b>
Name:	Name:
Date:	Date:
Signature:	Signature:

## ii Revision History

The following is a brief summary of the most recent revisions to the document. Details of all revisions prior to these are held by the issuing department.

<b>Revision No.</b>	<b>Date</b>	<b>Author</b>	<b>Scope / Remarks</b>
1.01			
1.02			
1.02b	21.02.2023	Paul France	Duct Access added
1.04	26.03.2023	Paul France	Modified to First Draft

# Table of Contents

- 1 PURPOSE AND SCOPE .....3
- 2 DEFINITIONS .....4
- 3 SERVICE DESCRIPTION .....5
- 4 RESPONSIBILITIES AND EXEMPTIONS .....7
- 5 TERM OF CONTRACT.....9
- 6 ORDERS AND DELIVERY .....10
- 7 SERVICE ASSURANCE AND PERFORMANCE .....11
- 8 PRICING.....12
- 9 FAULT HANDLING .....13
- 10 NETWORK OPERATIONS AND MAINTENANCE.....14
- 11 FORECASTS .....15

## **1 Purpose and Scope**

- 1.1** This Sub Annex sets out the terms and conditions under which Oman Broadband will provide the Duct Access Service across Oman Broadband's Access Network to Requesting Licensee, for the purpose of Requesting Licensee deploying fibre-optic cables to offer FTTH services.
- 1.2** A detailed description of Oman Broadband's Access Network and its various components can be found in Annex C.

## 2 Definitions

2.1 See Definitions in Annex A of the Agreement.

### 3 Service Description

- 3.1 Oman Broadband's Duct Access Service allows Requesting Licensee to utilise available space within Oman Broadband's FTTH Ducts to install its own fibre-optic cables.
- 3.2 Duct routes are provided on a point-to-point basis only, between designated Oman Broadband Chambers/Handholes.
- 3.3 Duct space is provided to Requesting Licensee as a separate Sub-Duct which is owned and maintained by Oman Broadband.
- 3.4 Once a Service Order has been agreed upon, Oman Broadband will provide and install Sub-Duct in an existing Oman Broadband Duct.
- 3.5 For the avoidance of doubt, a Sub-Duct may be utilised by only one Requesting Licensee.
- 3.6 The handover points for the Sub-Duct will always be located within a space provided by Requesting Licensee, such as a Handhole of Requesting Licensee, along with the connecting duct between the respective Handholes as illustrated in Figure 1 below.

*Figure 1: Overview of Oman Broadband's Duct Access product*

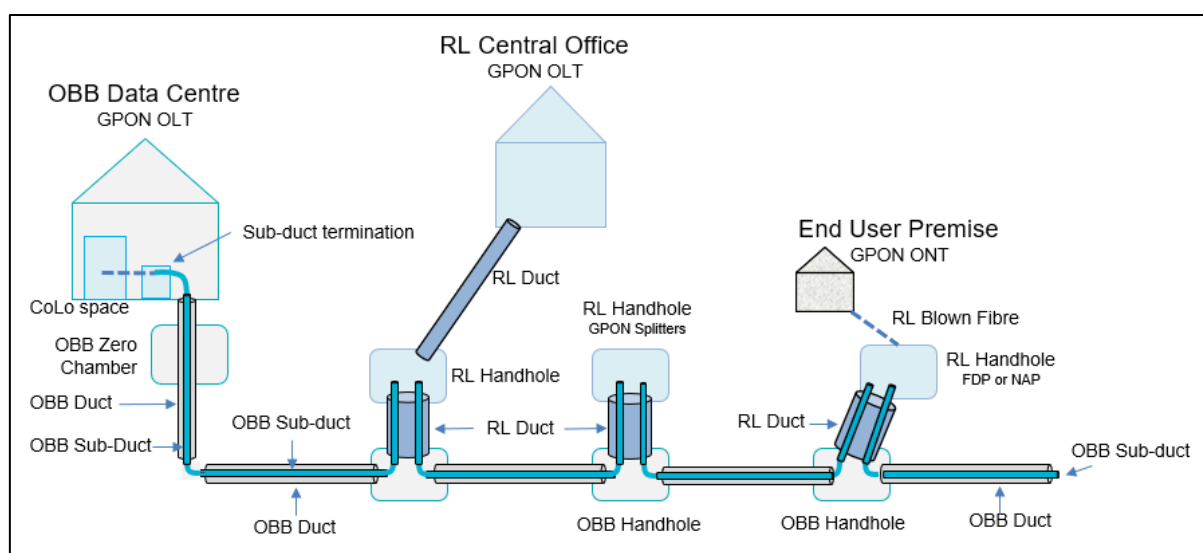

- 3.7 Sub-Duct is also available between an Oman Broadband Data Centre, through the Zero Chamber, and an available Handhole of Requesting Licensee as illustrated in Figure 1. This option allows Requesting Licensee to Co-locate in Oman Broadband's Data Centre.
- 3.8 If Requesting Licensee has constructed a connecting Duct from an Oman Broadband Chamber/Handhole to their own Handhole, then Sub-Duct will be provided to that Handhole.

- 3.9** Splitters and connectors or splices used to construct a Passive Optical Network must be supplied and installed by Requesting Licensee inside their own facilities such as Handholes, street cabinets or their own Central Office.
- 3.10** Similarly, Requesting Licensee is also responsible for providing and installing the connecting conduit to enter end-user premise using their own facilities.
- 3.11** Sub-Duct may only be used to install blown fibre or blown cable, in order to minimise operational impacts.

## **4 Responsibilities and Exemptions**

### **Responsibilities**

- 4.1** Oman Broadband is responsible for the provision of Sub-Duct between the end-points agreed upon with Requesting Licensee. Such end-points will always be located in facilities provided by Requesting Licensee such as Handholes.
- 4.2** Oman Broadband is also responsible for conducting a full feasibility study, as described in Clause 7 of Annex D.
- 4.3** Once the feasibility study is complete, Oman Broadband will share a feasibility report with Requesting Licensee, outlining the feasibility of providing Sub-Duct in the specific route(s).
- 4.4** All new permissions for work to be carried out by Requesting Licensee are the responsibility of Requesting Licensee.
- 4.5** Construction of facilities owned by Requesting Licensee, such as connecting Ducts and new Handholes, is the responsibility of Requesting Licensee.
- 4.6** Requesting Licensee is also responsible for the break-in of its connecting Duct into Oman Broadband Chambers/Handholes. Such work must be undertaken by suitably qualified people, and be subject to supervision by Oman Broadband, once the plans have been approved by Oman Broadband.
- 4.7** Oman Broadband reserves the right to refuse such work in certain circumstances as stated in Clauses 4.10, 4.11 and 4.12 below.
- 4.8** Notification to undertake the works must also be given to Oman Broadband with a minimum notice period of Ninety (90) Calendar Days.
- 4.9** Although Oman Broadband may provide the Duct to be used from Oman Broadband Chamber/Handhole to a Handhole of Requesting Licensee, it is the choice of Requesting Licensee to install the Duct in its network.

### **Exemptions and Exclusions**

- 4.10** Oman Broadband is exempt from fulfilling a Duct Access request if it is deemed that the request is unsuitable or that fulfilment of the request could potentially put Oman Broadband assets at risk.
- 4.11** Other exemptions include:



- (i) Requests for Duct Access on ducts that are not part of the FTTH Access Network of Oman Broadband;
- (ii) Cases where it is deemed there is insufficient space for a Sub-Duct to be installed safely without damage to existing cables;
- (iii) Cases where Duct space has been reserved for future capacity increases;
- (iv) Cases where Duct space has been reserved for future new products;
- (v) Cases where the Duct is or will be utilised for security services or special projects;
- (vi) Cases involving critical Duct routes where space is at a premium;
- (vii) Cases where Oman Broadband is utilising a Duct from a third party; and
- (viii) Other cases made in good faith with supporting reasoning.

**4.12** Further, the Duct Access Service excludes ducts that are used for:

- (i) Building entry conduits used for the final drop into the building (for example 25 mm conduit);
- (ii) Internal building conduits for example those installed in MDUs; and
- (iii) Conduits installed in compounds or other areas that are under private ownership.

## **5 Term of Contract**

- 5.1** The minimum contract term for Duct Access Service, an Indefeasible Right of Use (IRU) Service Agreement, shall be fifteen (15) years starting from the agreed start date of the IRU.
- 5.2** The contract term beyond the Minimum Contract Term shall be renewed based on further discussions with Requesting Licensee.

## **6 Orders and Delivery**

**6.1** Orders and delivery shall be as per Annex D.

## **7 Service Assurance and Performance**

**7.1** The service assurance and performance shall be as per Annex D.

## **8 Pricing**

**8.1** The pricing shall be as per Annex E.

## **9 Fault Handling**

**9.1** Processes for fault handling shall be as per Annex D.

## **10 Network Operations and Maintenance**

- 10.1** Maintenance and repair of Oman Broadband Sub-Duct used for Duct Access Service will be undertaken by Oman Broadband.
- 10.2** Maintenance and repair of fibre-optic cable installed by Requesting Licensee within the Sub-Duct will be undertaken by Requesting Licensee.
- 10.3** Maintenance and repair of the Sub-Duct may require Requesting Licensee to remove its fibre-optic cable as part of the repair.
- 10.4** In the event that installation, maintenance or repair of the fibre-optic cable by Requesting Licensee, causes damage to the assets of Oman Broadband, then Oman Broadband will make full claim for damages, including any penalties imposed by the TRA or other Requesting Licensees for loss of service or failure to meet SLAs.
- 10.5** In the event that Requesting Licensee needs to carry out planned maintenance on its fibre-optic cables, it shall provide Oman Broadband with at least twenty (20) Business Days' notice, along with a statement of the impact expected.
- 10.6** In the event of planned maintenance or repair work required by Oman Broadband, refer to Clause 8 in Annex D.
- 10.7** In the event of unplanned maintenance or repair work required by Oman Broadband, Oman Broadband shall notify Requesting Licensee of the necessary work that will be undertaken. As a result, Requesting Licensee may need to take remedial action. Temporary repairs may be required in some circumstances.
- 10.8** For other maintenance procedures refer to the Main Body of the Agreement and Annex D.

## **11 Forecasts**

**11.1** Refer to the Main Body of the Agreement.